



ADT925

Handheld Hydraulic Pressure Test Pump User's Manual

[Version number:1409V13]

Please download the latest version from www.additel.com



Warnings and cautions

- > Operate the pump in the rated pressure range and do not exceed the safety pressure of 9000 psi (600 bar).
- > Close the valves and tighten the ports when transporting the pump.
- > Always open the reservoir release valve during operation.
- > Do not over tighten the connectors or handles to avoid any damage.
- > Change contaminated media immediately.
- > Do not let the media level get below the mid line of the reservoir when the pump is place horizontal.
- > Keep the outer threads clean.
- > Additel is not liable for any safety problems or damages caused by misuse or incorrect operation.

Specification

- > **Pressure range:** 12.5 psi (0.85 bar) vacuum to 6000 psi (400 bar) positive pressure

*Remark: If local atmosphere pressure is 1 bar, the vacuum can reach to 0.85 bar;
If local atmosphere pressure is P, the vacuum can reach to (P - 85%) bar.*

- > **Temperature:** (0-50) °C
- > **Humidity:** < 95%RH
- > **Adjustment resolution:** 0.015 psi (1 mbar)
- > **Safety pressure:** < 9000 psi (600 bar)
- > **Pressure media:** Oil or deionized water

*To reach the best performance, oil is recommended.
Recommended oil: Di-ethylhexyl Sebacate, Isovoltine II.*

- > **Size:** Height: 4.72" (120 mm);
Base: 9.84" (250 mm) x 5.51" (140 mm)
- > **Weight:** 3.8 lb (1.7 kg) (excluding the media)

Configuration & Pressure drawing

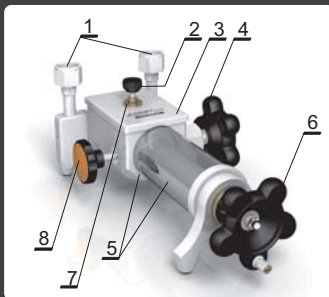

- 1 – Quick connector
- 2 – Reservoir release valve
(open it to connect with atmosphere)
- 3 – Upper cover of reservoir
- 4 – High-pressure pressurization and fine pressure adjustment handle
(clockwise to increase pressure)
- 5 – Liquid reservoir
(inner is pressure media)
- 6 – Pre-pressurization handle
(clockwise to increase pressure)
- 7 – Screw of fitting cover
- 8 – Vent valve
(Open to connect with atmosphere)

Pressure drawing

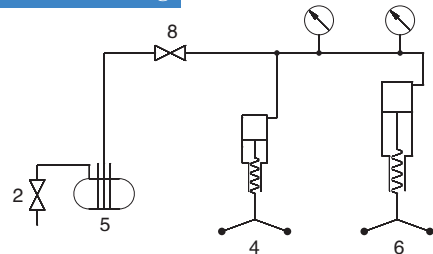

Troubleshooting

Problem	Cause	Solution
Difficult to increase pressure with pre-pressurization handle	A. Vent valve is not closed.	Close the vent valve.
	B. The O-ring seal is loose or damaged.	Replace the O-ring
	C. Not enough media is in the reservoir.	Fill with more fluid. Make sure fluid level is high enough after the gas purging process.
	D. The pump is not horizontal.	Place the pump horizontally to prepare for pressure or vacuum.
Hard to fine adjust	A. The vent valve is not closed.	Close the vent valve.
	B. The gauges are not connected tight.	Tighten the gauges.
	C. The sealing ring is aged or frayed.	Replace sealing ring.
	D. The thread surface is not smooth.	Use Teflon tape on the thread and turn it in tight.
	E. The connector type is mismatched to the gauge pressure port.	Use the correct adapter.
it is difficult to turn valves or quick connectors	A. Too much force was previously applied.	Do not over tighten.
	B. The pre-pressurization handle may not adjust easily under high pressure.	Adjust pressure by using fine adjustment handle. (Pressure may need to be decreased with the fine adjustment handle before the pre-pressure handle can be used).
	C. The threads have no lubrication.	Lubricate the thread.

O-Rings for pressure connector

P/N	Size	Connector
1611300004	4X1.5	M10X1, 1/8BSP, 1/8NPT
1611300220	6.5X3	M20X1.5, 1/2BSP, 1/2NPT
1611300024	6X2	M14X1.5, 1/4BSP, 1/4NPT, 3/8BSP

Preparation

Open the reservoir **A**

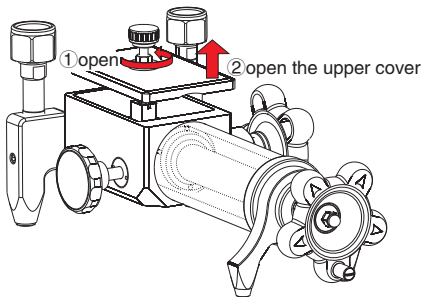

The media level should be 2/3 the height of the reservoir.

Filling/emptying the reservoir **B**

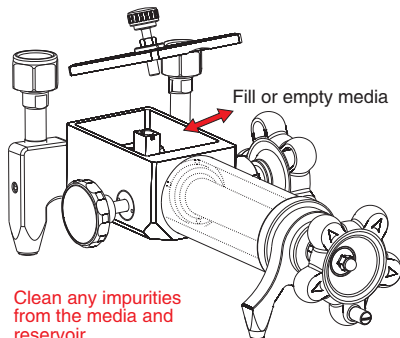

Clean any impurities from the media and reservoir.

Lock the reservoir **C**

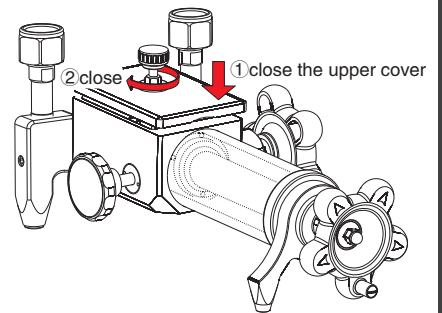

Basic Operation

Connection **A**

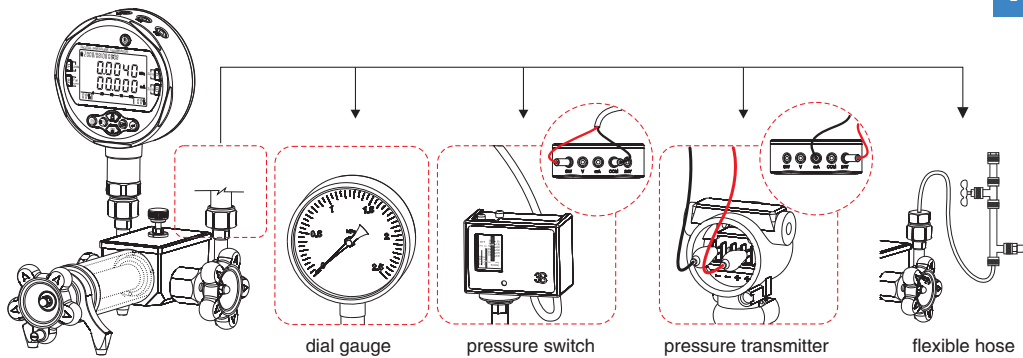

dial gauge

pressure switch

pressure transmitter

flexible hose

Vent **B**

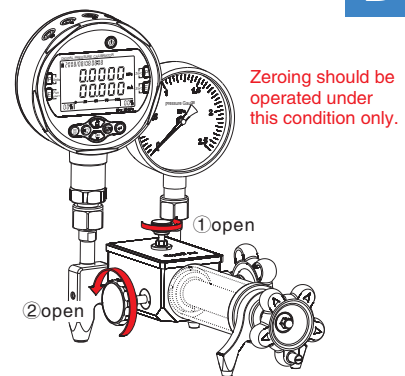

Zeroing should be operated under this condition only.

Purge process **C**

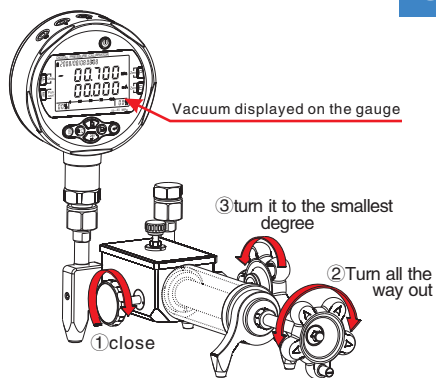

Vacuum displayed on the gauge

Purge process (cont.) **D**

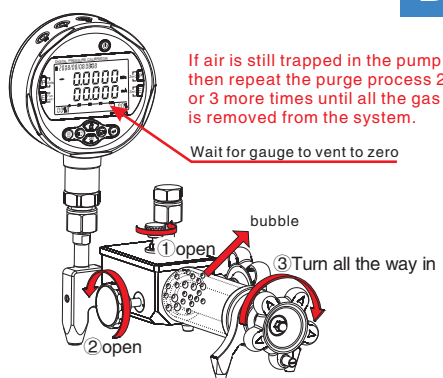

If air is still trapped in the pump, then repeat the purge process 2 or 3 more times until all the gas is removed from the system.

Wait for gauge to vent to zero

Pre-pressure **E**

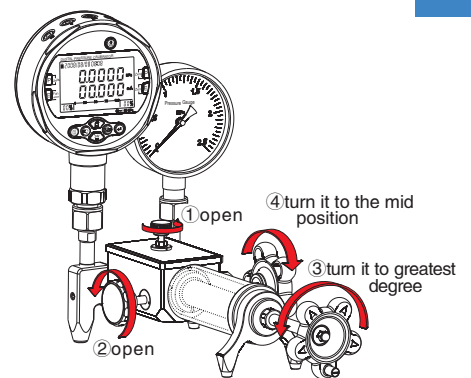

Pressurizing process **F**

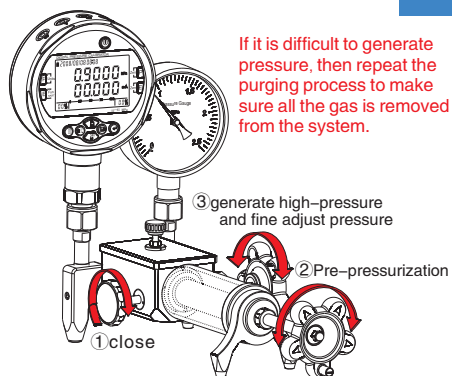

If it is difficult to generate pressure, then repeat the purging process to make sure all the gas is removed from the system.

Vacuum preparation **G**

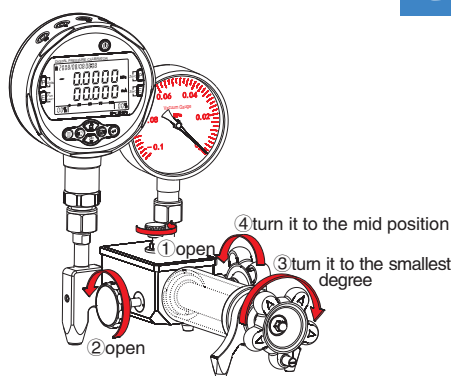

Vacuum process **H**

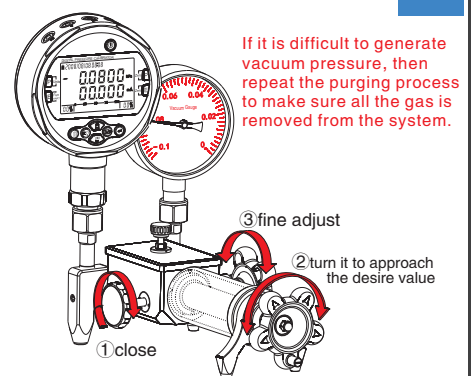

If it is difficult to generate vacuum pressure, then repeat the purging process to make sure all the gas is removed from the system.

Remark:

A: Additel has made a concerted effort to provide complete and current information for the proper use of the equipment. The product specifications and other information contained in this manual are subject to change without notice.

B: Above pictures are just for reference.